



▶ FEATURES AND BENEFITS
ADA / BARRIER-FREE
COMPLIANCY..... 1



▶ SPECIFICATIONS
ADVANTAGES
APPLICATIONS..... 2
CUT SHEETS 3



▶ INSTALLATION
LAMP REPLACEMENT
PARTS AND SERVICE .. 4

Lit Signage TechniEdge

TECHNICAL SPECIFICATONS
INSTRUCTION SHEET
AND USER GUIDE

Create outstanding visual impact with brilliant and eye catching graphics in either fluorescent or LED lit formats.

Features and Benefits

- A barrier free/ADA compliant signage system.
- Available in two formats—cool running high frequency electronic ballast and energy efficient T5 lamps or energy efficient LEDs.
- Each T5 fluorescent unit has a complete light fixture making lamp replacement easy.
- Very affordable graphics (etched on plastic) are easily changed. (not supplied)
- Available as a hanging, desk or wall mountable unit.
- Easily link signs end to end for greater visual impact
- Available single or double sided for added design flexibility.
- On our T5 fluorescent version, a detachable 2-prong cord with roll switch is available in a variety of lengths.
- The TechniEdge LED is operated with an AC adapter power supply.
- Available in 120v, 220v or 12v.



Above: the TechniEdge sign is available in two lit formats: the TechniEdge F – a T5 fluorescent model or the TechniEdge LED lit model

Below: the TechniEdge LED can be built in a variety of different coloured LEDs to complement your graphic.

Why Go Edge-lit?

Incorporating edge lighting with new types of light diffusing acrylic is a recent technological innovation in the trend of ultra-slim illuminated signage. An alternative to the standard backlit sign (which requires the use of deep sign cabinets to house the lamp fixtures and electronics) edge-lit signage minimizes heat build-up and surface hot spots. Illuminating signs from the edge—with a single fluorescent lamp enables the construction of significantly slimmer and more versatile signs that are barrier-free and easier to install. By moving away from the deep sign cabinets of backlit signage, TechniLite has incorporated lighting within the framed edge of the acrylic sheet to construct ultra slim, illuminated signage that offers improved flexibility. The flexibility of ultra-slim, edge-lit signage greatly facilitates its handling, allowing its graphic panel to be changed both quickly and easily. The benefits of this become clear when applied to high-traffic areas with limited space. Advertising displays are able to maintain extra-bright messaging, and their etched acrylic graphic panels can be swapped at a low expense.





- SPECIFICATIONS
- ADVANTAGES
- APPLICATIONS

Specifications TechniEdge

SPECIFICATIONS T5 MODEL

Lamp Types	T5 – Straight – Avg. nominal lengths (inches) 9, 12, 21, 22, 34, 46, 58 for both standard and high output
Number of Lamps	1 or 2 lamps (on a single extrusion)
Ignition Sequence	Instant start – Delayed
Line Voltage	12, 120, 220/240 and 347 V
Power Factor	Normal
Sound Rating	< Class A noise level
Starting Temperature	Minimum –15 °C/ 5 °F
High Frequency Operation	> 25 KHz
Input Frequency	50/60 Hz
Transient Protection	Meets IEEE 587 (ANSI 62.41) Category A
EMI	Meets FCC Part 18C Class A
End of Life	Ballast will not be damaged when operated with a rectifying lamp or if output shorted
RFI Noise Suppression	Optionally available
Ballast Topology	Cross section 1.1" X 1" cool running aluminum enclosure
Thermal Protection	Class P

ADVANTAGES

- barrier free/ADA compliant
- self contained, easy lamp replacement for T5 model
- Add a coloured gel to T5 models for easy colour changes
- changeable and affordable graphics
- hanging or wall mounted
- link signs end to end
- one or two sided
- T5 model—detachable 2-prong cord with roll switch in a variety of lengths,
- LED model comes with a 120 VAC adapter
- T5 model available in 120v or 220v; LED model available in 12 VDC or 120 VAC adapter

Right: the TechniEdge LED comes with a mounting bar that makes installation simple.

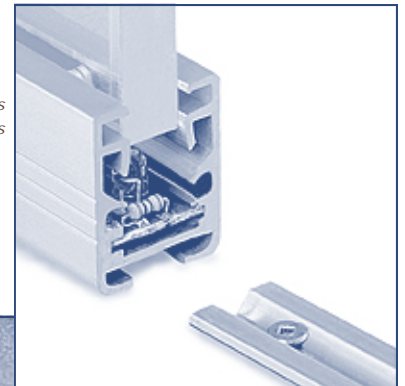

SPECIFICATIONS LED MODEL

- voltage: 12 VDC
- 120 VAC adapter available.
- 3 watts for 6" of light
- 50 lm/W
- colour temperature: 5400 K
- operating temperature: -25°C to 50°C

APPLICATIONS

- theatres, cinemas
- libraries, schools
- public spaces
- transit stations
- directories
- video stores
- museums

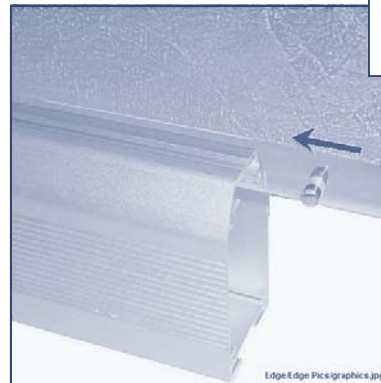

Left: the TechniEdge F offers easy graphic changes by simply removing the end cap and sliding graphic into

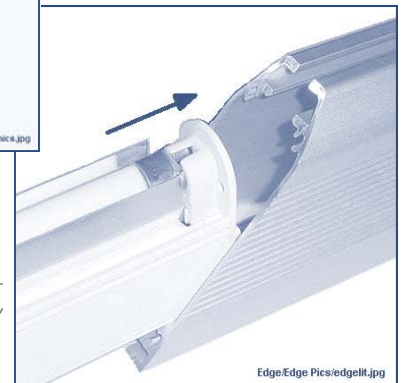

Right: the TechniEdge F provides for easy lamp changes with the easy removal of the extrusion end cap.



▶ CUT SHEET

Specifications TechniEdge

CUT SHEET

General Specifications: *(drawing not to scale)*

The 1/4" thick acrylic graphic is held securely by the extruded aluminum housing.

The graphic is illuminated by our T5 high efficiency lamps and is operated by an electronic ballast.

Power requirement: 120v 60 Hz.

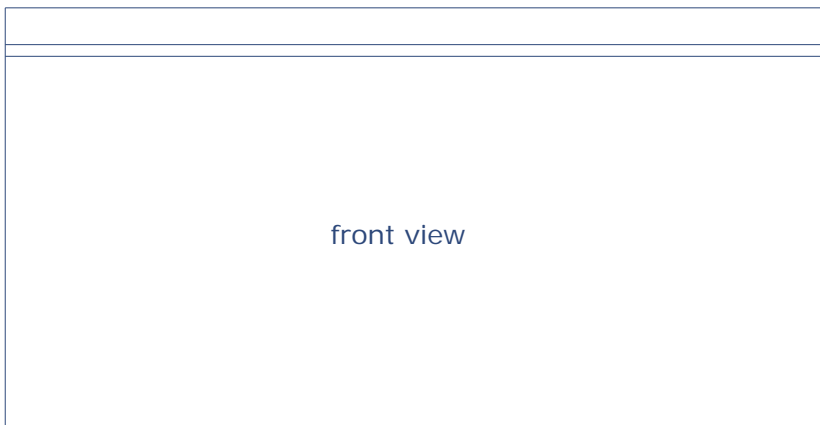
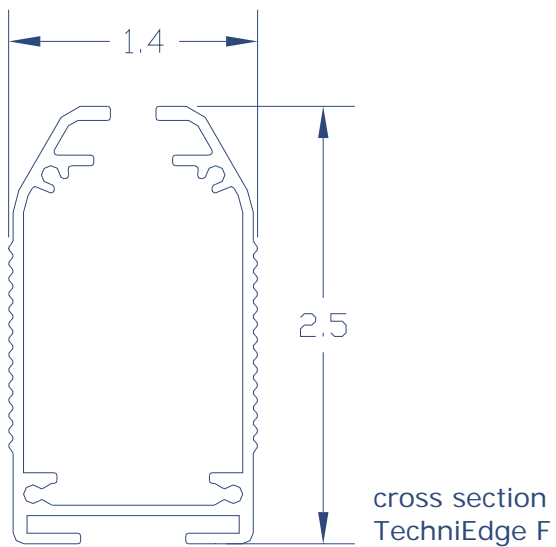
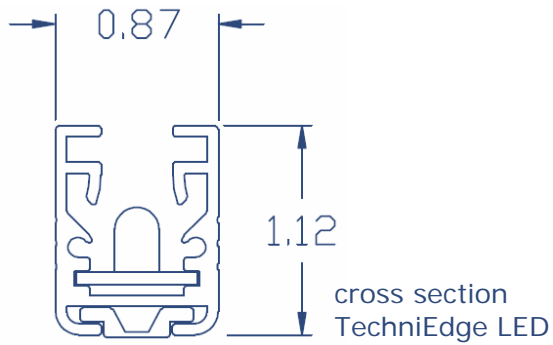



► INSTALLATION INSTRUCTIONS
LAMP REPLACEMENT
PARTS AND SERVICE

Use and Care TechniEdge

INSTALLATION TECHNIEDGE F

Tools required: #4 Philips screwdriver, #6 Philips screwdriver, 3/16" drill and bit, wall anchors (*not supplied*)

- Using a #4 Philips screwdriver, remove the power cord side end cap.
- Slide out the light assembly.
- Place the unit on wall in desired location.
- Using a pencil mark the location of the holes.
- Drill a 3/16" hole if not located on stud.
- Insert a #6 wall anchor.
- Place the unit over the holes.
- Install #6 -1" screws.
- Slide in the lamp assembly and graphic acrylic. (*see graphic installation below*)
- Reinstall the end cap.

Graphic Installation:

- Ensure graphic width is equal to or less than the extrusion length by measuring inside of end caps.
- In the bottom of graphic acrylic drill 2 - 3/16" diameter holes centred 5/32" up from edge.
- Insert the supplied 3/16" diameter rod (5/8" long) into your drilled holes and centre.
- Slide unit into groove.
- Secure end cap.

INSTALLATION TECHNIEDGE LED

Tools required: screwdriver, drill and 3/32" bit, additional drill bit, screws and wall anchors for mounting (*not supplied*)

- Using a screwdriver, remove the power cord side end cap.
- Slide out the mounting bracket.
- Place the mounting bracket on wall in desired location.
- Using a pencil mark the location of the holes.
- Drill a 3/16" hole.
- Insert a wall anchor.
- Place the mounting bracket over the holes.
- Install screws.
- Slide the LED assembly fixture over the mounting bracket. (*see graphic installation below*)
- Install graphic according to instructions below.
- Reinstall the end cap.
- Attach power supply and plug into receptacle.

Graphic Installation:

- Ensure graphic width is equal to or less than the extrusion length by measuring inside of end caps.
- In the bottom of graphic acrylic drill 3/32" diameter holes centred 5/32" up from edge.
- Insert the supplied 1/8" diameter rods (5/8" long) into your drilled holes and centre.
- Slide unit into groove.
- Continue installation instructions above.

LAMP REPLACEMENT

Ensure power is off (unplug cord or turn switch off) and then remove end cap from end of fixture. Remove lamp assembly. Remove lamp by rotating it 90°, unlocking it from the fixture. Replace lamp with same wattage, and lock into place by rotating the lamp 90°.

PARTS AND SERVICE

We pride ourselves in our commitment to quality and reliability of all our products. Our TechniEdge signs are warranted to be free of defects in workmanship. Ballasts are replaced by changing out whole fixture. Replacement lamps are readily available and can be ordered directly from TechniLite Systems by calling 1.800.730.5853.

