

### Wall mounting

1. The door can be unlocked with keys taped to the front of one or more of the signs. (Note: The same key is used for all signs at one location).
2. Open the door to gain access to the back panel. **Caution: The door opens only 90° - do not force door beyond this point.**
3. In order to access the back panel you will have to remove the poster frame by taking out the screws around the 3 sides.
4. After determining where the supporting studs are located; line up your drill holes with the studs and drill.
5. Each back lighted display unit weighs at least 50 pounds. Each mounting situation is unique.
6. It is essential that the appropriate screws/lag bolts are used when mounting the sign to the supporting flat surface.
7. Once all electrical connections and mechanical mounting work has been completed, insert the T5 or T8 lamps and apply power.
8. Reinstall the poster white.
9. Close the sign door and lock the unit.

### Electrical connection (for hardwire installation only - see fig.1)

Use the knockouts provided or drill a hole in the back panel to allow the wire to come through. (Note: this should be done in a way to meet local electrical codes.). Drill the hole close to the knockouts 1/3 or 2/3 of the way toward the ballast enclosure. Ensure the hole is away from where the closest lamp will be located. (Example: 6" in from edge of sign and up 18" for 57" x 32")

1. Remove the ballast raceway cover.
  2. Feed wires through the knockout.
  3. Connect the ground to the ground stud and connect the power wires according to your local electrical codes.
  4. Reattach the ballast cover.
  5. Insert the T8 lamps and apply power by turning on switch (if applicable).
- Caution: Use only T5 or T8 lamps as presently installed.**

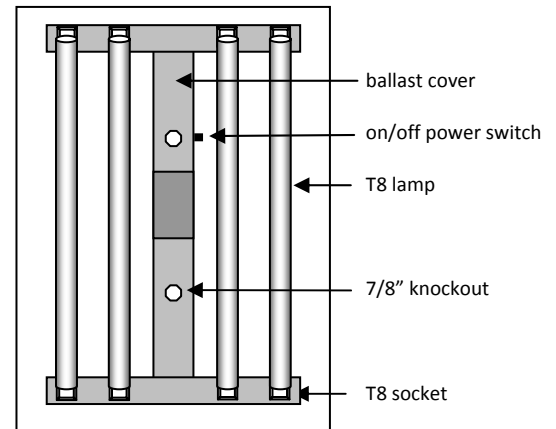

(fig. 1) T8 fluorescent configuration

### Poster changes

1. Unlock door by quarter turn of locks (Note: All doors are opened by the same key at one location).
2. Poster is held in place by a plastic clip located at the top of the poster frame. This will hold the poster firmly in place.
3. Close sign door and lock the unit.

### Lamp changes (Please note that lamps are already installed and tape is to be removed from lamp end before operation of the sign)

1. Unlock door by quarter turn of locks.
2. Remove the poster white.
3. Make sure power to sign is off.
4. Remove the T5 or T8 lamps.
5. Replace the burned out lamps with new ones. Use only F32 T8 or F25 T5 or T8 lamps for this application. This is achieved by carefully PLACING the ends of the lamps into the empty socket outlets (once the old lamps have been removed). A recommended maintenance practice is to change all lamps at once to maintain equal light distribution and minimize number of changes.
6. Turn the power to sign on.
7. Reinstall the poster white.
8. Close sign door and lock the unit.

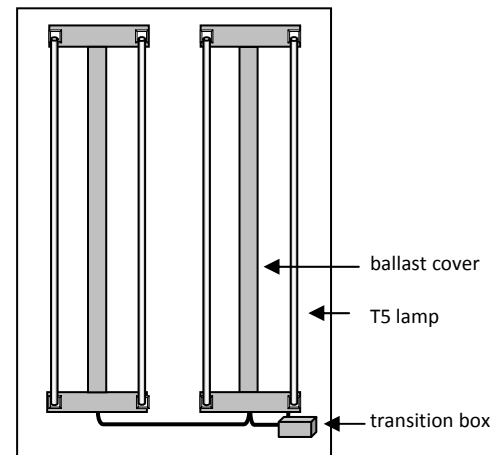

(fig. 2) T5 fluorescent configuration

### Cleaning

Clean glass gently with window cleaner. Clean clear Lexan and acrylic with warm water and a soft clean cloth. **Caution: do not use petroleum based or abrasive cleaners.**

**\*\*This sign is intended to be installed in accordance with the requirements of "Article 600" of the "National Electrical Code and/or other local application codes. This includes proper grounding and bonding of the signs. \*\***